

PRODUCT CATALOG

Automation Without Bounds

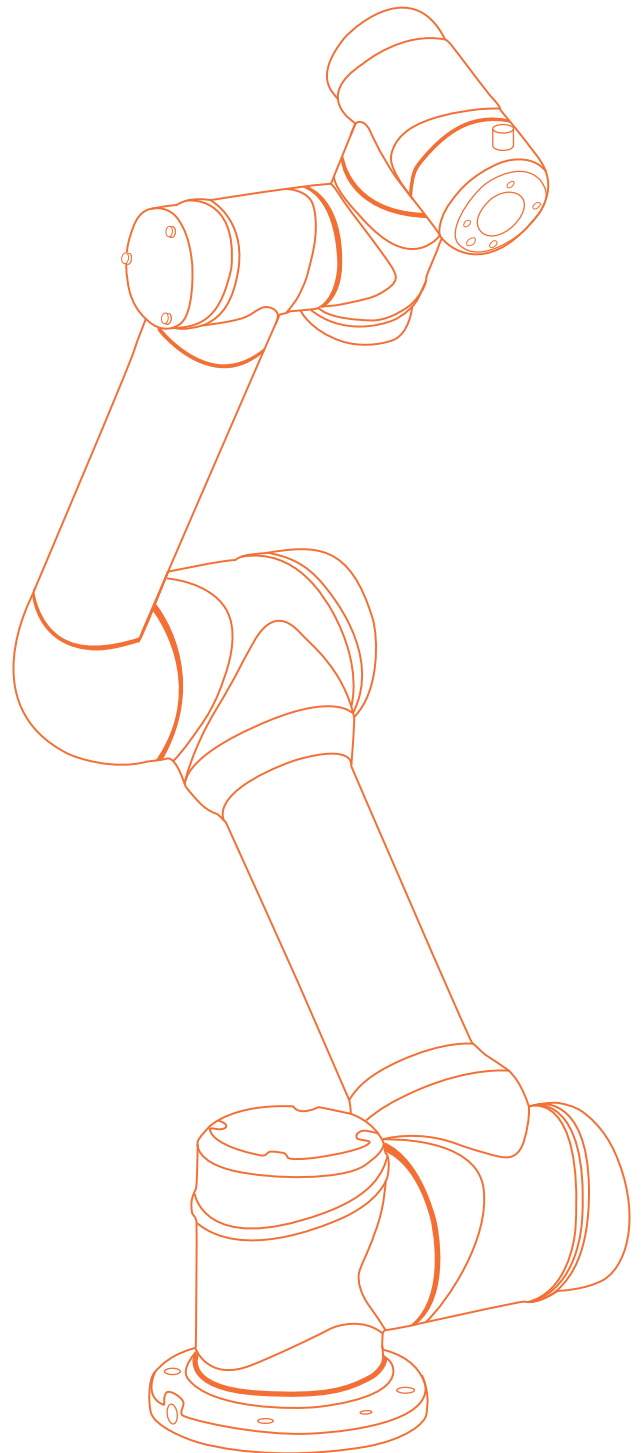

www.aubo-usa.com



Building a more collaborative future,
one cobot at a time.

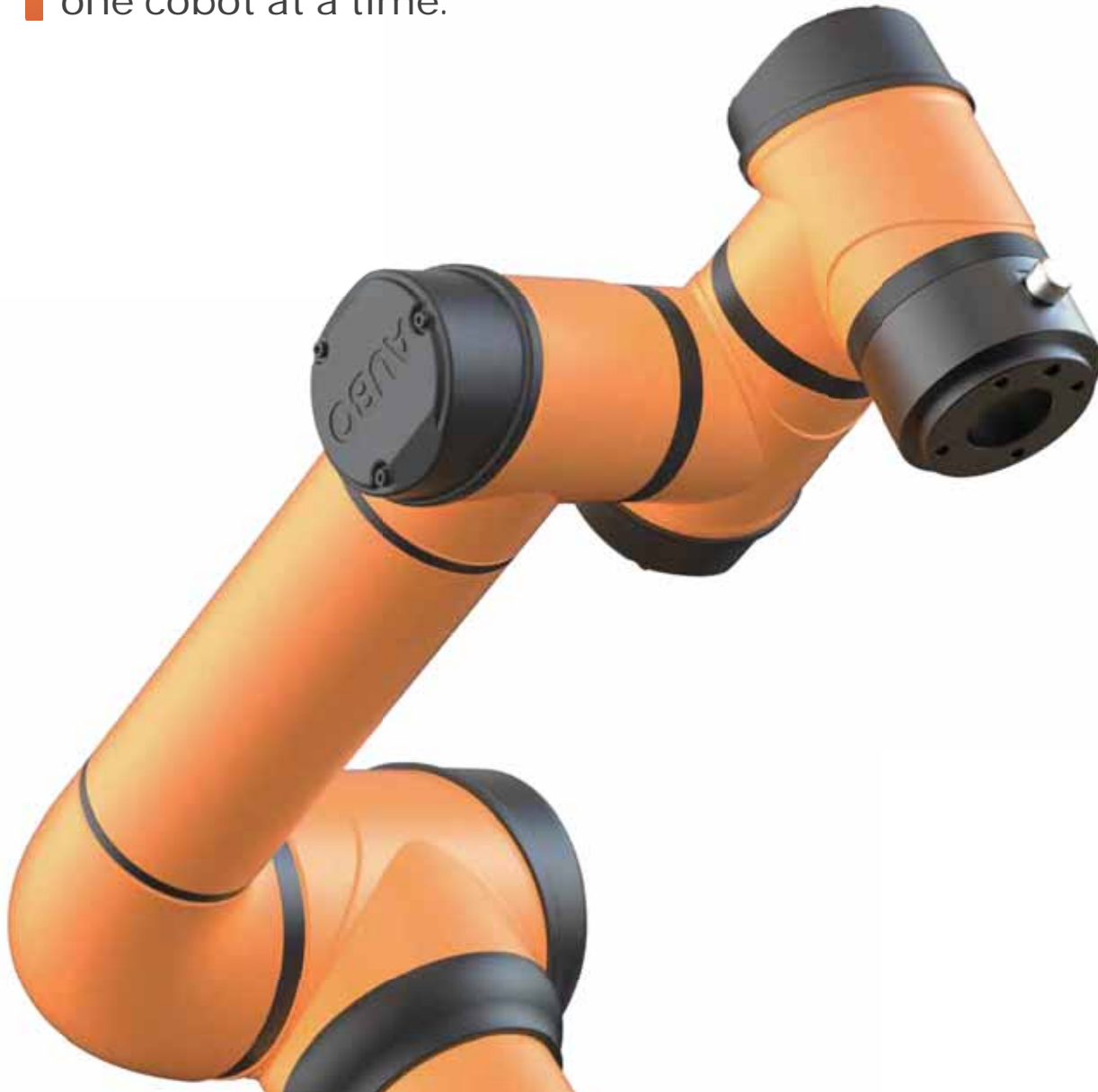

TABLE OF CONTENTS

	Pg. #
About Us	
Introduction Who is AUBO?	01 02
Company History	03 04
Production & Testing Safety Certifications	05 06
i-Series Collaborative Robot Line	Pg. #
i-Series Introduction The AUBO Advantage	07 08
Deep Dive: The i-Series Cobots	09 10
Application Case Studies	Pg. #
Automotive	11 12
Parts Production Therapeutics	13 14
Mobile Cobots Cobots & Emerging Tech	15 16
Service and Support	Pg. #
Serving North America U.S. Based HQ & Service	17 18
Specifications & Technical Comparison	19 20
Dimensional Drawings: Part 1	21 22
Dimensional Drawings: Part 2	23 24

AN OPEN SOURCE COBOT

Built for the future of human progress.



Discover the value of reliability.

WHO IS AUBO?

Building a more collaborative world

AUBO Robotics creates open architecture, precision-calibrated, simple-to-operate collaborative robots. In 2010 AUBO Robotics started developing their first robot at the University of Tennessee – originally in pursuit of creating a robot that served well for the classroom and education setting. In time, the team began researching and developing industrial applications, quickly cementing itself as a global leader in cobot production and APAC's leading industrial collaborative robot manufacturer.

Based in Detroit, Michigan, AUBO Robotics USA exclusively serves the North American Market. Our US Headquarters includes our warehouse, service department, training center, and technical, customer, and sales support teams. Dedicated to the US market, we are motivated by results and driven by the success of our customers, helping you build custom automation solutions to accelerate growth and build ROI.

We believe that with the right approach, automation will change the course of human progress for the better – replacing occupations prone to safety hazards and pushing manufacturers to develop their labor's human capital. As such, we set out to create automation solutions that work alongside humans and are accessible to any business while bringing value and customization back to your production workflow.



COMPANY HISTORY

Start-up at the University of Tennessee

2010

Commencement of R&D

The AUBO team launches the research and development of collaborative robots for education at the University of Tennessee.**

2012

The first AUBO R&D Center is established

The team establishes a dedicated independent research center and begins development toward the i-Series cobots.

2014

The leadership team is assembled

A team of dedicated professionals and automation experts formally establishes the leadership for what will eventually be known as AUBO Robotics.

2016

Going into production

The AUBO-i5 collaborative robots go into production with assembly, testing, and shipment at the Jiangsu Changzhou Production Facility to support public demand.

2018

All cobots pass EN ISO 13849-1:2015 (PL=d, CAT 3) security certification

AUBO Robotics becomes the first cobot manufacturer in China to pass the EN ISO 13849-1:2015 certification.

2020

Expanded testing and QA process

With all models receiving UL certification in late 2017, AUBO invested deeply in the testing and quality assurance capabilities, expanding facilities at the main production center to support a full-scale testing hall.

2022

Launch of the AUBO i20 collaborative robot

AUBO launched the i20 - a high-performance collaborative robot with access to override lockouts offering functions that, until now, were only possible with industrial robots.

2011

R&D shifts to industrial applications

Following breakthroughs in the development process, the team pivots to research industrial applications for APAC.

2013

Debut of the first-generation cobots

The early concepts and first-generation of AUBO collaborative robots appear.

Development

2015

AUBO is established as a global entity

AUBO Robotics Technology Co., Ltd. is established through an angel investment of 8.6 million with a subsidiary in Germany, with offices in Shenzhen and Shanghai following shortly after. The AUBO-i5 collaborative robot receives a global launch becoming the first i-Series cobot.

2017

UL Certification

A talented team of globally respected scientists and engineers join the organization to ensure engineering and test standards.

All cobots are officially UL certified.

Building the ecosystem

2019

New cobots join the i-Series

The AUBO i-Series expand payload capacity with the AUBO i3, i10, and i16 launching globally. The AUBO i7 and i12 launch across APAC.

2021

Sales exceed 10,000 Units Worldwide

Exceeding goals and sales forecasts, AUBO sells 10,000 units globally.

Products receive SEMI S2 certification.

The Future of AUBO

2023

AUBO Expands US Operations

With a US-based team, AUBO opens its US Headquarters in Romulus, Michigan. Offering benefits like a US warehouse with in-stock cobot parts and arms, training and service centers for dedicated support and resources, and a varied ecosystem of products through channel partners consisting of distributors, integrators, and OEMs.



METICULOUSLY DESIGNED, RIGOROUSLY TESTED

We push our cobots to the limit – so you can too. Our test protocol of over 160 tests includes vibration, high temperature, part wear, performance at age, repeatability, operating noise, laser calibration, precision, and more – we ensure the reliability, quality, and durability of our products are at their pinnacle before a single cobot leaves our production floor.

Production Capacity

AUBO’s production base, located in Changzhou City, covers an area of 12,000m², and has an annual production capacity of 10,000 units. Our vertically integrated manufacturing process and ownership of the supporting systems within our supply chain allow us to control even the slightest inconsistencies to ensure the pinnacle of durability, lifespan, and design. As a result of this manufacturing process, AUBO's supply chain was largely unaffected during the global supply chain crisis. Contrarily, AUBO grew its market share and offered customers a reliable supply.

Assembly & Quality Control

27 IQC Tests **163** Test Standards **76** Test Instruments

Component QA

354 Test Standards **126** Test Instruments

Final QA

58 Final QA Tests **21** Test Instruments



Testing and Quality Assurance Hall

PRODUCT SAFETY CERTIFICATIONS

We’ve spent the last 12+ years improving every aspect of our cobots to make them safer and more stable. All AUBO Cobots are certified EN ISO 13849-1:2015 (PL=d, CAT 3), UL, CE, and SEMI S2 compliant, so you can count the reliability and safety of our cobots throughout your ownership.

Certified compliant with ISO 13849-1, CE, UL, SEMI S2, and ISO 14644-1



EN ISO 13849-1:2015(PL=d, CAT 3)

CE

UL



SEMI S2



ISO 14644-1:2015

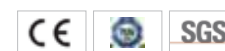

BUILT FOR COLLABORATION

Our flagship cobots combine ease of use, precision, and safety you can trust. AUBO Developed the i-series line with open-source architecture in mind: designed to be simple to operate out of the box while retaining full-programming customizability unlocking your team's ability to benefit from the flexibility to automate any process in your workflow.

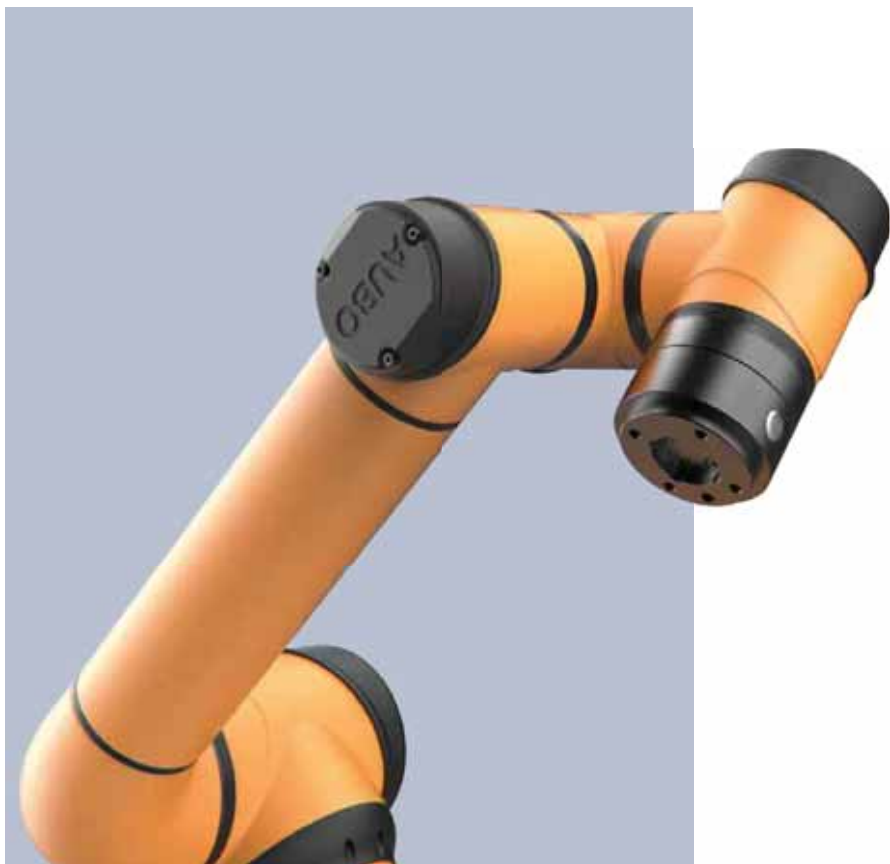

THE AUBO ADVANTAGE



Flexible Deployment

- AUBO cobots are lightweight and compact, featuring a minimal footprint for easy deployment across applications – within four hours on average.
- With 6-degrees of freedom, each cobot is designed to retain flexibility regardless of the work space.



Easy to Program & Operate

- Out-of-the box, it takes less than 30 minutes for an untrained user to learn how to program their first simple task.
- Our teach pendant features a simple to use visual drag and drop system for cobot operation, so you can realize the full benefits of automation without coding experience.



Safety Features

- The i-Series cobots are certified EN ISO 13849-1:2015 (PL=d, CAT 3), ISO/TS 15066:2016 (excluding i20**) UL, CE, and SEMI S2 compliant.
- 10-levels of customizable collision detection and sensory safety.
- In the case of power loss: every joint activates a braking system to lock it's position, even when holding objects.
- The 16 safety I/O interfaces feature redundant design and ensure the continued operation of safety features in the case of a single port failure.



Modular Design

- Every joint in an AUBO Cobot is designed to be fully modular, so in the rare case that a cobot needs servicing any joint can be swapped out quickly and easily.



High Repeatability

- Millisecond-level system response ensures high repeatability.
- Up to ±0.02mm repeatability.



Never Proprietary

- AUBO cobots feature ISO 9409-1-50 mechanical interfaces, allowing easy integration with all standard end-of-arm tooling.
- Our cobots do not require a specific ecosystem of products or software and feature fully open source architecture .



Application Agnostic

- i-Series Cobots are built to integrate fully and easily into your existing application workflow. Regardless of the use case or industry, we can help customize a solution for you.



Open Source Architecture

- AUBO Cobots are open source and allow full customization by end-users.
- We provide SDKs in C, C++, C#, Lua, and Python for 32 & 64-bit Linux and Windows, and support for ROS.
- Communication protocols include: Ethernet TCP/IP, ModBus-RTU/TCP, and Profinet.
- Support for custom plugin development.
- Public access to AUBO's Virtual Machine for sandbox development and testing environment.



High Return on Investment

- We control every aspect of our supply chain, allowing us to deliver the best value to our customers while retaining exceptional quality - from every component to the final assembly. The cost of initial investment is recovered on average within the first year.



Endless Customizability

- Nearly every aspect of our automation solutions are fully customizable. If you can't find an out of box solution to fit your needs we can connect your team to our vast ecosystem of partners to help you customize a solution that is specific to your use case.

i SERIES COLLABORATIVE ROBOT

The i-series cobots combine ease of use, precision, and safety you can trust. Developed with fully open source architecture, the i-Series is designed to be simple to operate out of the box while retaining full-programming customizability and support for custom plugins - making them the ideal choice for a collaborative automation solution.



AUBO i3

Payload: 3kg
Weight: 16kg
Repeatability: ± 0.02 mm
Reach: 625mm

Highly flexible, the i3 is our most compact, lightweight cobot. Thanks to its small footprint it shines in tight clearances and small workspaces – be it benchtop or inside machinery. While small, the i3 retains full-degree rotation on all wrist joints making it the perfect choice for light assembly and repeated movement applications.



AUBO i5

Payload: 5kg
Weight: 24kg
Repeatability: ± 0.02 mm
Reach: 885.6mm

The AUBO i5 is designed to afford all the flexibility possible without sacrificing its lightweight footprint. Thanks to its size and payload capacity of 5kg the i5 excels in a wide range of applications while retaining an excellent reach of 885.6mm that results in ultimate versatility to perform medium-duty applications.



AUBO i10

Payload: 10kg
Weight: 38.5kg
Repeatability: ± 0.03 mm
Reach: 1350mm

The AUBO i10 sports a 10kg payload capacity and is built to serve in wide workspaces for medium-duty applications. With a reach of 1350mm, the i10 can safely work from a distance without sacrificing payload capacity, performance, or precision.



AUBO i16

Payload: 16kg
Weight: 38kg
Repeatability: ± 0.03 mm
Reach: 967.5mm

The AUBO i16 is built to handle heavy-workloads with excellent precision and speed. It's high payload capacity in tandem with ability to pick up multiple objects at once helps drastically shorten production time. The i16 is also well-suited for use cases that require heavy end-of-arm tooling.



AUBO i20

Payload: 20kg
Weight: 63kg
Repeatability: ± 0.1 mm
Reach: 1650mm

The i20 medleys the best of safety and precision from collaborative robots with all the toughness you'd expect from an industrial robot. The i20's ability to handle heavier loads coupled with a smaller footprint than industrial robots in its class makes it the perfect solution for businesses looking to achieve top-tier performance in their workflows with power and force-limiting technology.

Automotive

Precision Material Application & Removal

A well-known automobile company approached us requesting a custom implementation for windshield gluing & sealing applications. Due to safety restrictions and space constraints, traditional industrial robots with fencing is too large for this working environment, taking up much-needed space that human labor on the production line uses to inspect the quality of the final product.



These i5 installations allowed for quick and pain-free deployment providing a small footprint with a uniform repeatability of $\pm 0.5\text{mm}$ for this application at exceptional speed, improving the quality and accuracy of the gluing and sealing process while ensuring the safety of factory and production workers without disrupting the existing human-centric production line processes.

Continuous Efficient Operation

Since its implementation in August 2019, these cobots have been running with minimal downtime at 16 hours a day, retaining excellent operating conditions and efficiency. This custom application has completely replaced the need for a manual gluing applicator and works longer hours without introducing unnecessary safety risks to human labor.



Automotive

Screwing, Fastening, and Torquing

A renowned automotive manufacturer approached our team to help build an automation system for their engine assembly line renovation project. Previously, screw fastening operations for this assembly line were completed primarily by humans, a labor-intensive process, prone to inconsistency in quality.

The challenge with this application was the fixed patterns of the screwing sequences. Additionally, the screws are divided into 5 categories with more than 100 sub-categories, requiring visual identification for each screw. After properly identified each screw would need to be torqued to a unique specification with high accuracy and repeatability.



The solution was a custom terminal screwing device based on an AUBO i5 with controllable screw gun end effector - which allowed compact structure and precise control of the torque spec for each screw. We also implemented hand-eye application with the vision system directly attached to the i5 arm, ensuring high positioning repeatability and quick identification of the various types of screws and sub categories of parts.

Reduced Manual Labor and Increased Productivity

Since its implementation in April 2019, production efficiency in this assembly line has increased by 18%, with a positive increase of 12% to the overall production yield, and a reduction in half of the human labor resulting in a 30% reduction in labor cost year on year.

FEATURED APPLICATION CASE STUDIES

Parts Production

Machine Tending

Below is the production line for a company that mainly produces precision machinery parts - they approached our team to find a collaborative automation solution that would support their business growth.

Traditionally, the parts manufacturing industry relies on manual labor for quality control and parts sorting. Due to the large variety of part types, in the original production environment, a single employee could only feasibly supervise two machines (before automation). Increased demand for parts combined with the slow production time led to higher employee retention costs, and additional expenses to find and train new employees.



The solution needed to be flexible and compact, collaborative, and feature a long reach; to allow the client work within the original production line without changing the layout. This led to implementation of a series of AUBO i10, due to its small footprint, long reach (up to 1350mm), human-centric nature, and excellent application for pick and place use cases for multiple machines.

Flexible Deployment

The i10 Cobots in this configuration complete pick and place tasks for two machines at once. Thanks to the open-source nature of the i-Series, the client created a series of scripts that allowed for an improved production workflow where each employee works alongside the cobots to tend to 6 machines – an impossibility with traditional industrial automation.



By effect, the implementation of cobots has tripled the scale of production. Meanwhile, the overall employee base has not undergone significant changes, saving costs on onboarding and training while supporting long-term business growth.

Therapeutics

Massage Cobot - Direct Human Contact

Traditional medicine is of great significance in Chinese culture, and Traditional Chinese Massages are a popular form of treatment for cervical, and lumbar care, or pain management – much like Chiropractic Care in North America. As such, AUBO developed the Massage Therapy Robot alongside a technology partner to simulate a traditional Chinese massage experience.



An ambitious project – we've developed a solution that allows direct human-to-robot contact, using the cobot arm to decompress and massage tense points in the body in a safe, temperature-controlled, sanitary manner.

The end of the cobot is equipped with a force sensing module, a 3D vision sensor, a massage head, and thermal imaging. In tandem with open-source scripting, the cobot arm glides across the back of the user to massage specific points with no more pressure than a human elbow or palm. The imaging tools, sensors, and the cobot's internal safety features ensure safe and stable operation. Making this project a true feat of engineering and design – demonstrating the precision, safety, and human-centric capabilities of what is possible with open-source collaborative robots.

Mobile Cobots

Testing and Packaging

Pictured is an AUBO Mobile cobot implementation inside a packaging and inspection workshop of a semiconductor manufacturer. Currently, semiconductor processing is heavily reliant on manual labor – which introduces problems in the consistency and durability of the final product due to particle pollution, segmented operation, part mishandling, and large vibrations.



The workshop needs to maintain a high level of cleanliness to meet its ISO certification, features a complex layout, limited space, and a wide variety of equipment with discrete production processes and complex technological processes; the situation demanded a flexible solution with a high safety and cleanliness rating, that could retain mobility.

This AUBO Mobile Cobot installation has effectively created an intelligent and unmanned production workshop. The mobile cobot navigates the room through hybrid positioning and natural navigation technology, and features indoor positioning repeatability of ± 5 mm. Equipped with a 360° dual safety LiDAR sensor, the AMR identifies objects and intelligently avoids them, ensuring safe and fast operation.

Reducing the Costs of Labor

This solution allows for 24-hour continuous operation, which helps alleviate labor costs, and solves information flow conversion. Due to the safety and cleanliness ratings of our cobots – the installation complies with the safety and cleanliness standards of the workshop, which assisted this manufacturer in retaining their certifications.



Cobots and Emerging Technology

Fully Unmanned Operation Using AI, Big Data, and Edge



An ongoing project for a client in the electric power industry, pictured is an AUBO mobile cobot manning the inspection of an electrical service distribution room - across this industry, it isn't uncommon to see bottlenecks due to a reliance on manual inspection. Frequent inspection is necessary, as the electrical equipment in this distribution room operates year-round, so parts are prone to failure. The need for a physical presence stems from the inability to remotely control the switches on the low-voltage arrays in rooms like these.

In cooperation with China Unicom, AUBO helped develop a solution that automates the process. These cobots operate on edge through a dedicated 5G network – ensuring safe, secure, and reliable operation. The mobile cobots use big data image recognition to intelligently distinguish equipment error codes and fault signals. Each mobile inspection cobot can complete more than ten functions, such as equipment inspection, device panel control, faulty part replacement, device reboot, and switch toggle. Additionally, much like a human writing a report, the cobots collect and store viewable records in the case of equipment malfunction.

The Power of Cobots and Emerging Tech

Thanks to their incredible operating safety, task precision, and overall reliability these mobile inspection cobots can be monitored entirely remotely, and do not require any personnel onsite to operate. As an intelligent solution that uses AI and big data to adapt to problems, rather than respond to pre-scripted protocols. This solution is an exemplary demonstration of what is possible in collaborative robotics.

DEDICATED TO NORTH AMERICA

The smartest choice for adopting a collaborative automation workflow - based in Detroit, Michigan, AUBO Robotics USA exclusively serves the North American Market. Our dedicated US Headquarters is home to our warehouse, service department, training center, technical support, customer, and sales support teams. That means faster lead times than the competition since all of our Cobot Arms destined for the United States ship directly from Michigan. Plus, we offer US-based service and support so you can be confident in the long-time support of your purchase.

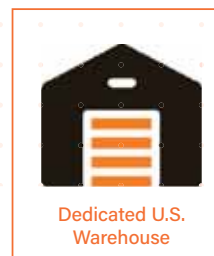

Our U.S. warehouse stocks cobot parts, arms, and full assemblies for the entire i-Series line, so you can expect fast lead times and shipping.



We offer expedited shipping on all orders destined for the United States thanks to our in-stock U.S. based parts and arms.



Need a hands on look? We're confident you'll love what you see. We offer cobot demonstrations at our headquarters and through our network of partners.



Our U.S. headquarters houses a full-service training facility and classroom for our customers and network of value-added partners.



In the rare occasion of component failure, we offer prompt and hassle-free RMA and Servicing - send the broken section of the arm to our U.S. Headquarters and we'll fix it or send a replacement right away. We also offer United States-based technical phone support on all AUBO products.

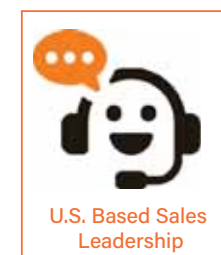

Our sales teams are United States-based. With sales leaders headquartered in the Midwest, Western, and South-Eastern United States. AUBO USA's Network of Value-Added Partners consists of distributors, integrators, and OEMs across North America.

Model	i3	i5	i7**	i10	i12**	i16	i20
Robot Degrees of Freedom	6	6	6	6	6	6	6
Reach (mm)	625	886.5	786.5	1350	1250	967.5	1650
Payload (kg)	3	5	7	10	12	16	20
Weight (kg)	16	24	24	38.5	40	38	63
Mounting Surface Diameter (mm)	Ø140	Ø172	Ø172	Ø220	Ø220	Ø220	Ø260
Repeatability (mm)	±0.02	±0.02	±0.02	±0.03	±0.03	±0.03	±0.1
Linear Velocity (m/s)	≤1.9	≤3.4	≤3.0	≤4.0	≤3.8	≤3.0	≤2.6
Average Power (W)	150	200	200	500	500	600	1000
Peak Power (W)	1000	2000	2000	2000	2000	2000	3000
Ambient Temperature (°)	0-50	0-50	0-50	0-50	0-50	0-50	0-50
Ambient Humidity	90% RH (Non-condensing)	90% RH (Non-condensing)	90% RH (Non-condensing)	90% RH (Non-condensing)	90% RH (Non-condensing)	90% RH (Non-condensing)	90% RH (Non-condensing)
Installation Orientation	Any ceiling, Floor, Wall	Any ceiling, Floor, Wall	Any ceiling, Floor, Wall	Any ceiling, Floor, Wall	Any ceiling, Floor, Wall	Any ceiling, Floor, Wall	Any ceiling, Floor, Wall
IP Classification	IP54	IP54	IP54	IP54	IP54	IP54	IP54
ISO 14644-1 Cleanliness Class	5	5	5	5	5	5	5

Axis Movement	Working Range (°)		Maximum Speed (°/s)		Working Range (°)		Maximum Speed (°/s)		Working Range (°)		Maximum Speed (°/s)		Working Range (°)		Maximum Speed (°/s)	
	Min	Max	Min	Max	Min	Max	Min	Max	Min	Max	Min	Max	Min	Max	Min	Max
Joint 1	±360	178	±360	223	±360	223	±360	178	±360	178	±360	178	±360	178	±360	93
Joint 2	±360	178	±360	223	±360	223	±360	178	±360	178	±360	178	±360	178	±360	93
Joint 3	±360	178	±360	223	±360	223	±360	223	±360	267	±360	267	±360	267	±360	178
Joint 4	±360	237	±360	237	±360	237	±360	178	±360	178	±360	178	±360	178	±360	178
Joint 5	±360	237	±360	237	±360	237	±360	237	±360	178	±360	178	±360	178	±360	178
Joint 6	±360	237	±360	237	±360	237	±360	237	±360	178	±360	178	±360	178	±360	178

*Each joint has ±360° of freedom, but depending on application and environment rotation may be limited.

Category	Control Box	Control Box I/O/Tool I/O	Control Box	Tool End
Control Box Model	AUBO-CB-M	I/O Port	Digital In	16 (general) /16 (safe)
Dimensions	390mm*370mm*265mm/410mm*390mm*285mm (i20)	Digital Out	16 (general) /16 (safe)	4 (optional)
Weight	15kg/16kg (i20)	Analog In	4	2
Cabling Connecting the Robot	5m (customizable, up to 8m)	Analog Out	4	-
Cabling Connecting the Teach Pendant	4m	I/O Power Output Voltage	24V	0V/12V/24V
Cabling Connecting the Power	5m	Output Current	3A Max	0.8A
Power Supply	100-240VAC, 50-60Hz			
Interface	Ethernet, ModBus-RTU/TCP, Profinet (Optional)			
Communication	SDK (Support C/C++/C#/Lua/Python) , Support ROS, API			
IP Classification	IP43			



Teach Pendant	Model	AUBO-TP
	Dimensions	355mm*235mm*54mm
	Weight	1.57kg
	IP Classification	IP43



Teach Pendant

SPECIFICATIONS & TECHNICAL COMPARISON

i7 and i12 only available through custom order.**

i3 DIMENSIONAL DRAWINGS

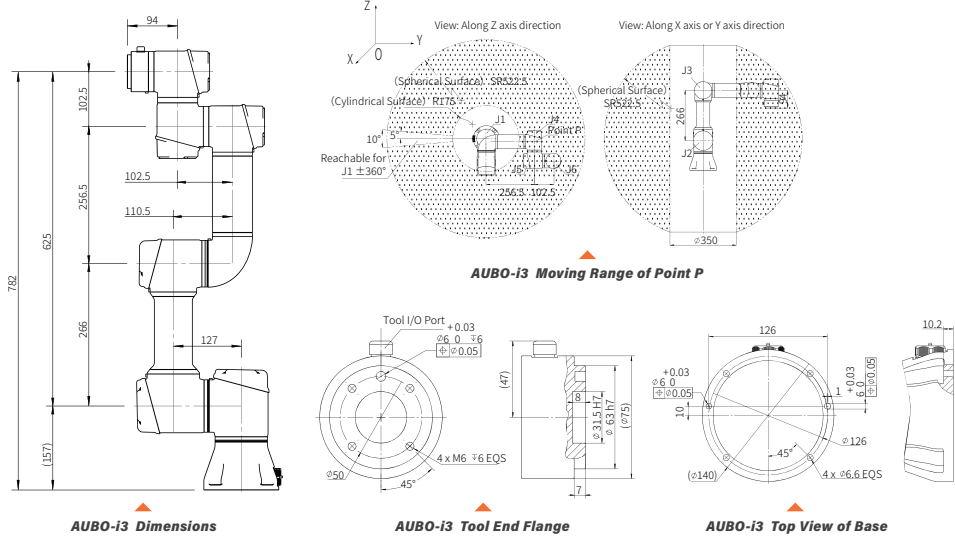

i10 DIMENSIONAL DRAWINGS

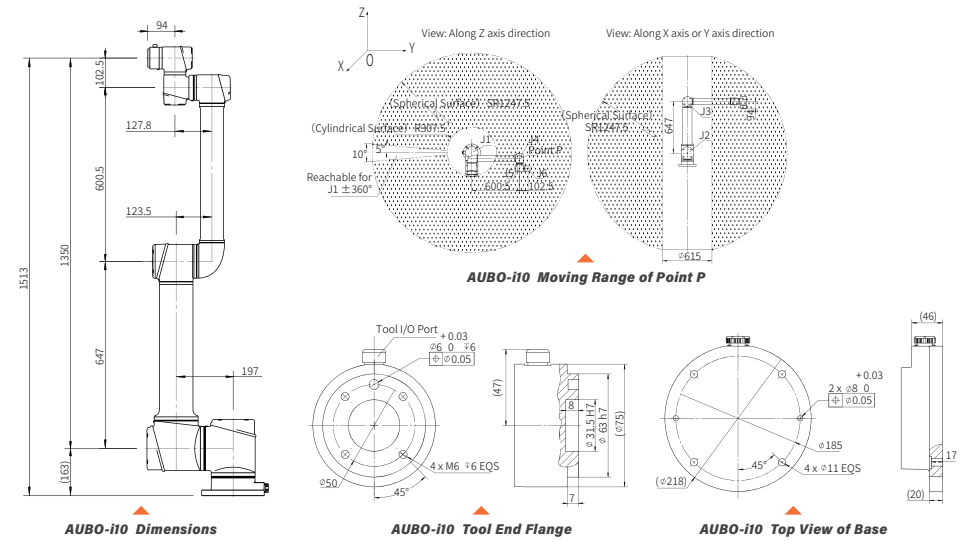

i5 DIMENSIONAL DRAWINGS

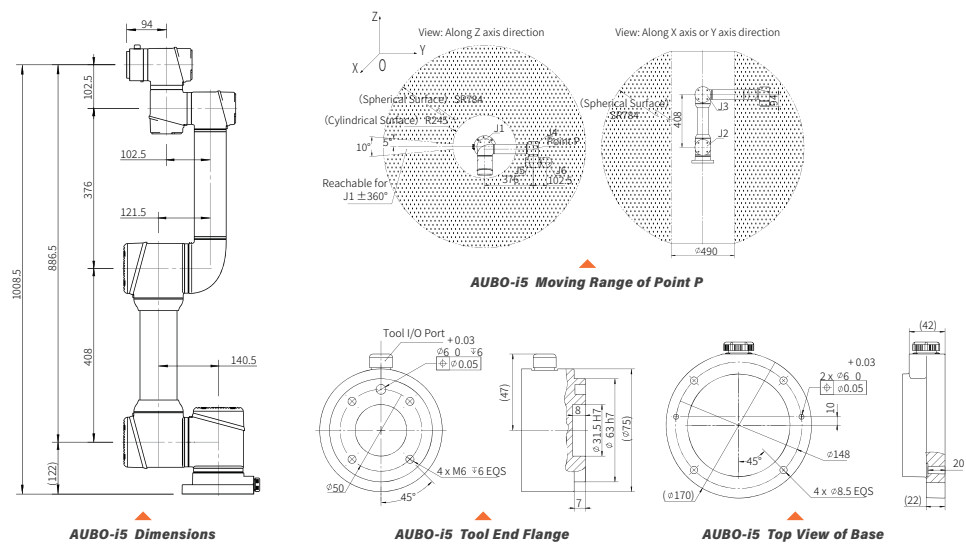

i16 DIMENSIONAL DRAWINGS

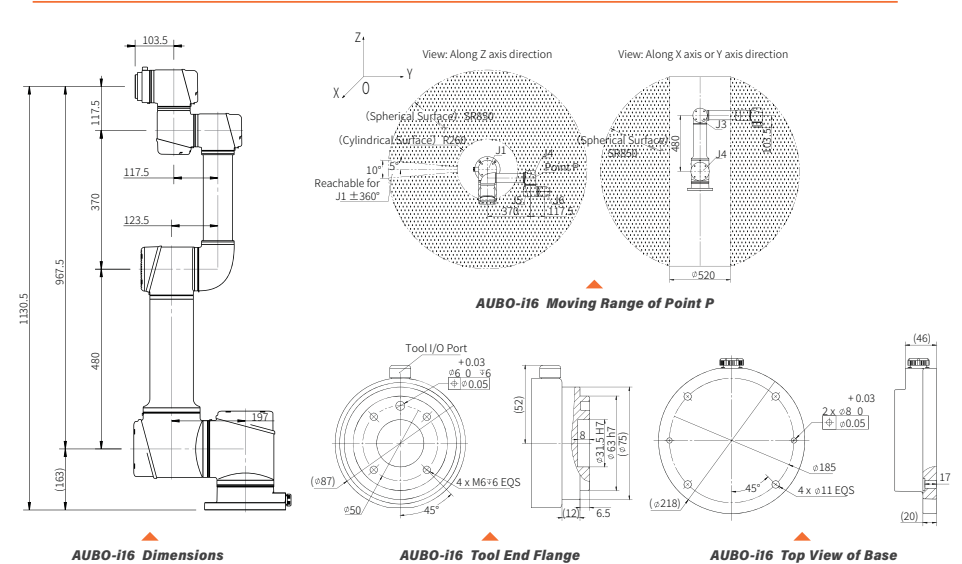

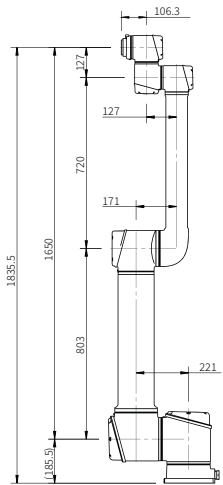

AUBO-i20 Dimensions

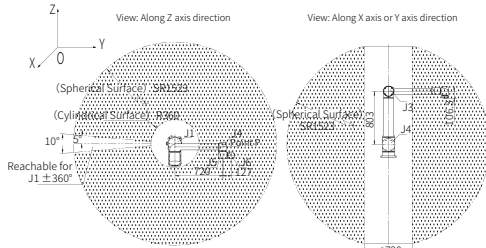

AUBO-i20 Moving Range of Point P

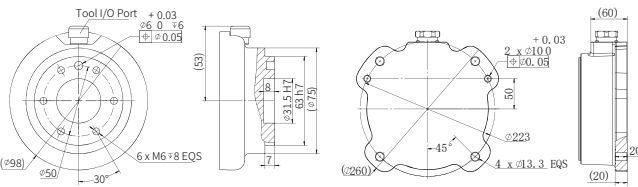

AUBO-i20 Tool End Flange

AUBO-i20 Top View of Base

Unlock Your Automation Potential

Compare the AUBO i-Series Cobots online at www.aubo-usa.com

