



AUBO i10

Technical Specifications & Data Sheet

6 Axis
10kg Payload
1350mm Reach

Your AUBO Distributor



Partners in Productivity

icrservices.com
(586) 582-1500



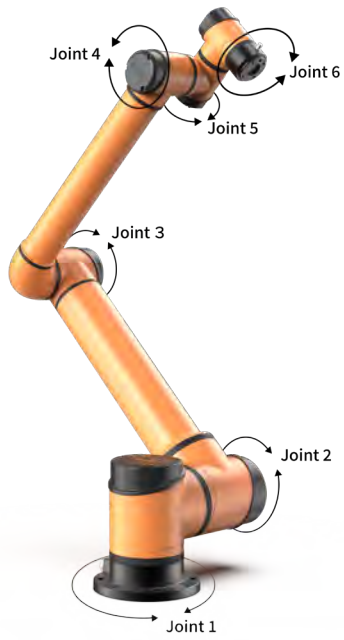

SPECIFICATIONS

Payload	10 kg
Reach	1350 mm
Weight	38.5 kg
Mounting Base Footprint	Ø220 mm
Avg. Power Consumption	500 W
Peak Power Consumption	2000 W
Operating Temperature	0-50 °C
Humidity	90% Relative Humidity (No Condensation)

CONTROL BOX SPECIFICATIONS

Size (L x W x H)	390mm x 370mm x 265mm
Weight	15 kg
Robot Cable Length (Customizable)	5 m
Teach Pendant Cable Length	4 m
Power Supply Cable Length	5 m
Communication Protocols	Ethernet TCP/IP, ModBus-RTU/TCP, Profinet
I/O Ports	
Digital Input	16 (User) / 16 (Safety)
Digital Output	16 (User) / 16 (Safety)
Analog Input	4
Analog Output	4
I/O Power Supply	24V 3A
Power Supply Requirements	100-240VAC, 50-60Hz
Open Source Development Support	SDKs in C/C++/C#/Lua/Python, ROS, Plug-in Support

MOVEMENT

Repeatability (ISO 9283)	±0.03 mm
Tool Velocity	≤4.0 m/s

Axis Movement	Working Range	Maximum Speed
J1 Base	±360°	178°/s
J2 Shoulder	±360°	178°/s
J3 Elbow	±360°	223°/s
J4 Wrist	±360°	178°/s
J5 Wrist	±360°	237°/s
J6 Wrist	±360°	237°/s

FEATURES

Mounting Orientation	Any Orientation
IP Classification	IP 54
ISO 16444-1 Clean Room Level	Class 5

Tool I/O Ports	
Digital Input	4 (Customizable)
Digital Output	4 (Customizable)
Analog Input	2
Analog Output	-

I/O Power Supply	
Output Voltage	0V/12V/24V
Output Current	0.8A

The AUBO i10 is designed to excel in wide workspaces for medium-duty applications. With a 10kg payload capacity, it provides the strength and versatility required for various tasks. Featuring a remarkable reach of 1350mm, the i10 can safely operate from a distance, without compromising on performance or precision.

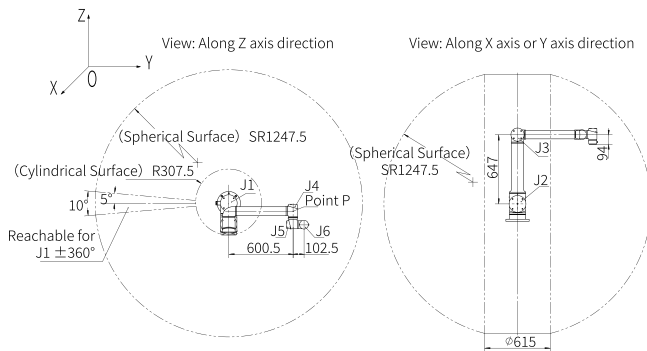

WORKSPACE DIMENSIONS

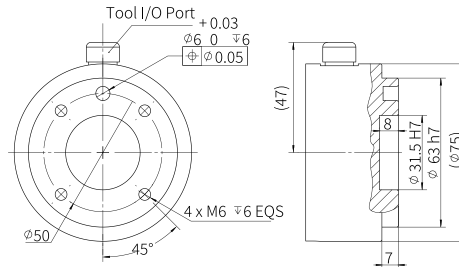

END FLANGE DIMENSIONS

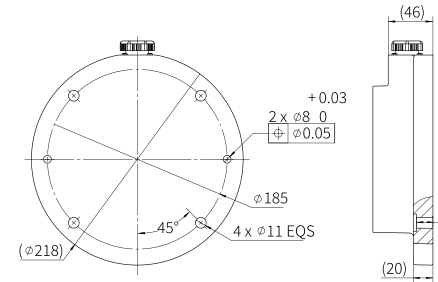

ROBOT BASE TOP VIEW

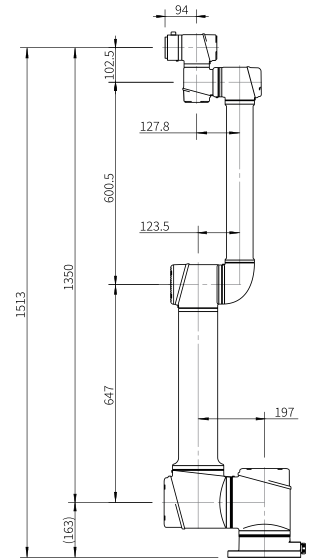

PRODUCT DIMENSIONS