



# AUBO i5s

Technical Specifications & Data Sheet

6 Axis  
5kg Payload  
886mm Reach

Your AUBO Distributor



icrservices.com  
(586) 582-1500



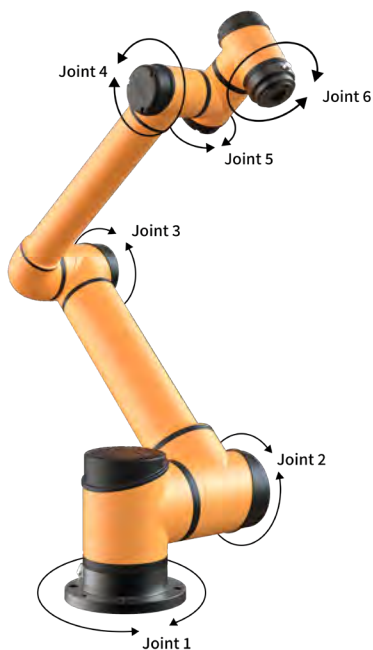

## SPECIFICATIONS

Payload	5 kg
Reach	886.5 mm
Weight	24 kg
Mounting Base Footprint	Ø172 mm
Avg. Power Consumption	200 W
Peak Power Consumption	2000 W
Operating Temperature	0-50 °C
Humidity	90% Relative Humidity (No Condensation)

## CONTROL BOX SPECIFICATIONS

Size (L x W x H)	390mm x 370mm x 265mm
Weight	15 kg
Robot Cable Length (Customizable)	5 m
Teach Pendant Cable Length	4 m
Power Supply Cable Length	5 m
Communication Protocols	Ethernet TCP/IP, ModBus-RTU/TCP, Profinet
<b>I/O Ports</b>	
Digital Input	16 (User) / 16 (Safety)
Digital Output	16 (User) / 16 (Safety)
Analog Input	4
Analog Output	4
I/O Power Supply	24V 3A
Power Supply Requirements	100-240VAC, 50-60Hz
Open Source Development Support	SDKs in C/C++/C#/Lua/Python, ROS, Plug-in Support

## MOVEMENT

Repeatability (ISO 9283)	±0.02 mm	
Tool Velocity	≤3.4 m/s	
Axis Movement	Working Range	Maximum Speed
J1 Base	±360°	223°/s
J2 Shoulder	±360°	223°/s
J3 Elbow	±360°	223°/s
J4 Wrist	±360°	237°/s
J5 Wrist	±360°	237°/s
J6 Wrist	±360°	237°/s

## FEATURES

Mounting Orientation	Any Orientation	
IP Classification	IP 54	
ISO 16444-1 Clean Room Level	Class 5	
<b>Tool I/O Ports</b>		
Digital Input	4 (Customizable)	
Digital Output	4 (Customizable)	
Analog Input	2	
Analog Output	-	
<b>I/O Power Supply</b>		
Output Voltage	0V/12V/24V	
Output Current	0.8A	

The AUBO i5s is designed to afford all the flexibility possible without sacrificing a lightweight footprint. Thanks to its size and payload capacity of 5kg the i5s excels in a wide range of applications while retaining an excellent reach of 886.5mm that results in ultimate versatility to perform medium-duty applications. The powerful motors in the AUBO i5s enable it to outpace the standard AUBO i5 significantly in speed of operation.

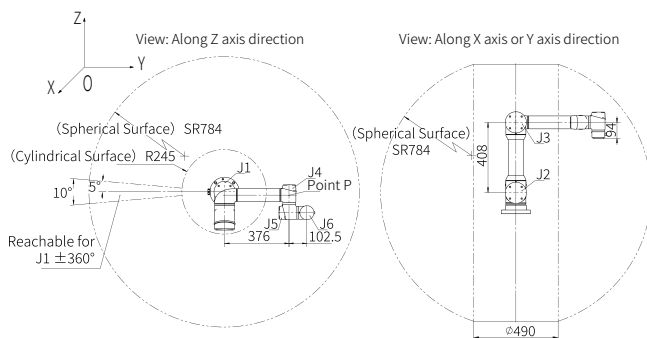

WORKSPACE DIMENSIONS

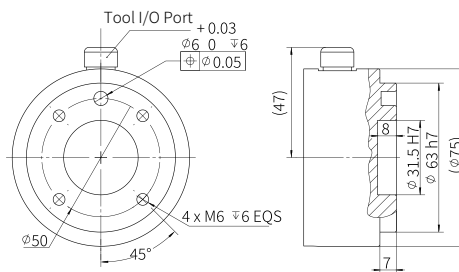

END FLANGE DIMENSIONS

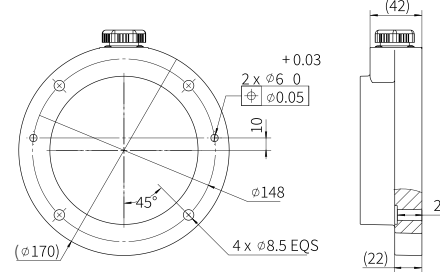

ROBOT BASE TOP VIEW

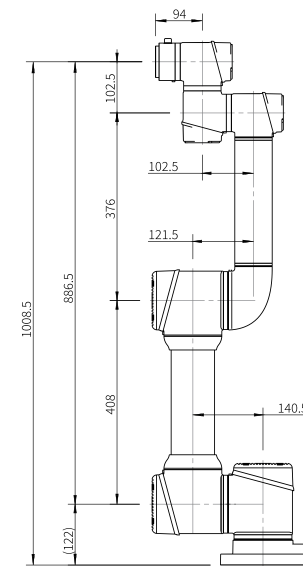

PRODUCT DIMENSIONS